

FLOWSEAL®

Butterfly Valves Series HP



FLOWSEAL-Butterfly Valves

Series HP

High Performance process valves for industrial applications

Areas of application

Flowseal is a leading provider of soft seat, metal seat and fire-safe high performance butterfly valves. Our products are manufactured under an ISO 9001 Quality Assurance Program that ensures each valve we produce meets or exceeds your exacting application requirements.

Flowseal high performance butterfly valves are a standard in many industries including heating, ventilating and air conditioning, power generation, hydrocarbon processing, water and waste water treatment, and marine and commercial shipbuilding. Our products are also installed in applications as diverse as food and beverage processing, snowmaking and pulp and paper production. Configurations are available for harsh conditions as well as applications requiring nominal pressure and temperature ratings.

As part of Crane Valve Group, Flowseal high performance butterfly valves are backed by the resources and experience of one of the world's largest valve producers with a delivery and quality track record that is unparalleled in the industries we serve.

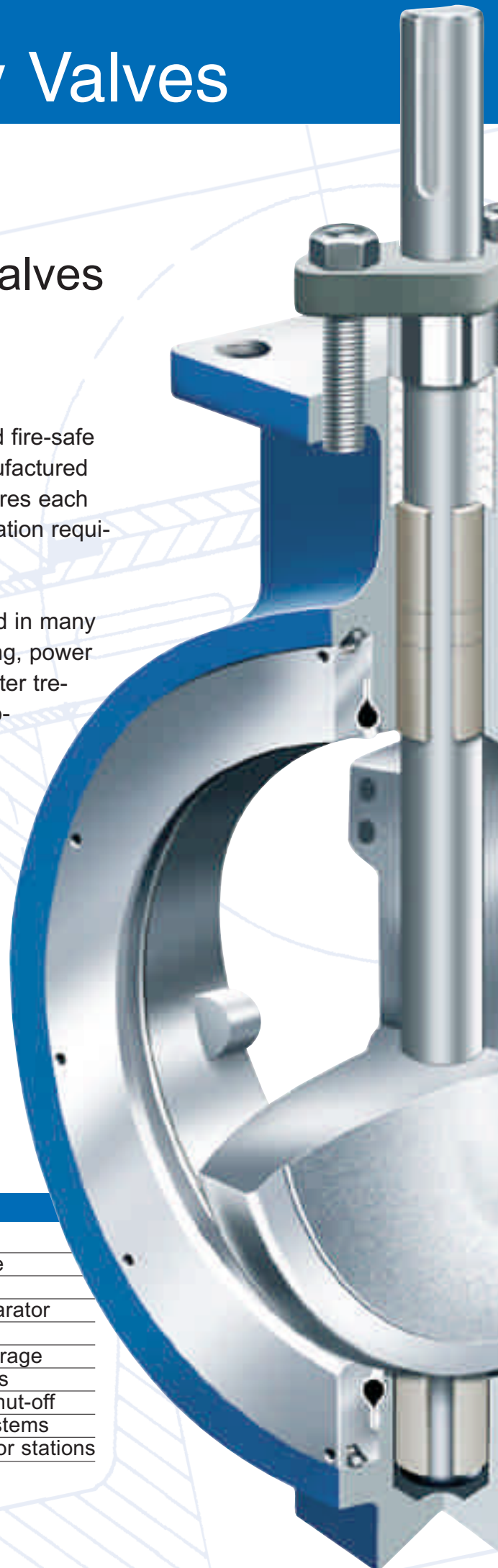

Main areas of application:

- Chemical
- Marine and Shipbuilding
- Petroleum Refining
- Power Generation
- Pulp and Paper
- Commercial Constructions
- Transmission
- Mining
- Snowmaking Systems
- Water and Sewage

Applications:

- Gas dryer / separation
- Waste water discharge
- Hot water
- Sugar / molasses separator
- Fresh and sea water
- Jet and Diesel fuel storage
- Fire protection systems
- Bottom ash / fly ash shut-off
- Chemical recovery systems
- Natural gas compressor stations

For highest demands over a wide range of pressures and temperatures

Pressure / Temperature Ratings:

As temperature increases, the pressure retaining capability of materials decreases. The graph below illustrates the pressure/temperature ratings of the Flowseal ANSI Class 150, Class 300 and Class 600 for sizes 2" to 48".

ANSI B16.34 Body and Flowseal Soft Seat Pressure - Temperature Ratings

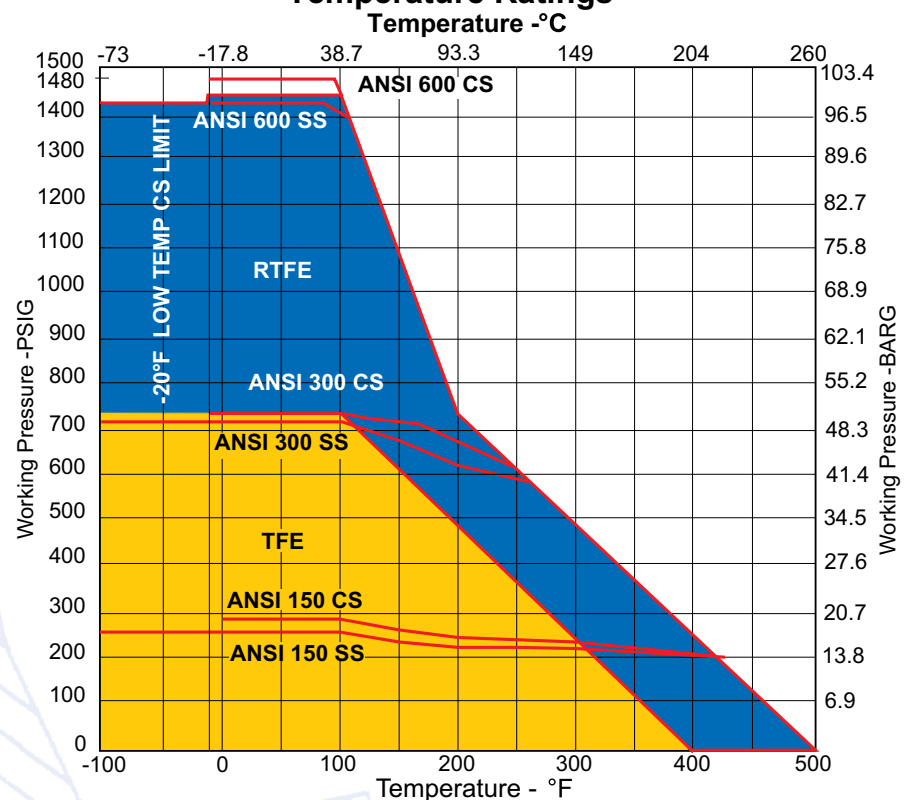

The heavy lines define the ratings of the carbon steel and stainless steel valve body (or "shell") in conformance to ANSI B16.34. The shaded areas define the ratings of the soft seat.

Seat ratings are based on differential pressure with the disc in the fully closed position.

Soft Seat Design

The Flowseal Soft Seat valve provides a bi-directional bubble tight shutoff (zero leakage) by the use of a patented seat. This unique seat design creates a self-energized seal in vacuum-to-low pressure applications. Under higher pressure conditions, the seat is also designed to permit, confine and direct movement of the soft seat against the disc edge, up to the full ANSI Class 150, 300 and 600 Cold Working Pressures.

DISC SPACERS

Disc is centered by use of thrust spacers around shaft in sizes 2" to 5". Disc position stops or thrust bolt arrangements are used for larger valve sizes.

WEDGE PINS

Provide positive mechanical attachment of disc to shaft.

RETAINER RING

Retains seat in valve. Standard surface finish is 125 to 200 AARH and is compatible with both standard gaskets and spiral wound gasket designs. Outside diameter is recessed within gasket sealing surface to prevent external leakage.

OVERTRAVEL STOP

Prevents disc from rotating into wrong quadrant.

DISC

360° uninterrupted spherical edge for sealing. Profile is designed for maximum flow and equal percentage control.

SET SCREWS

Cone point screws force wedge ring outward to lock seat retainer in position on valve sizes 2" through 30". Socket head cap screws are used on valve sizes 36" and larger.

SOFT-SEAT

Bi-directional seat with encapsulated elastomeric o-ring core for resiliency. Common seat materials include TFE, RTFE and UHMWPE.

WEDGE RING

Stainless steel band wedged between valve body and retainer ring by set screws to lock seat and retainer ring in position on valve sizes 2" through 30". Socket head cap screws are used on valve sizes 36" and larger.

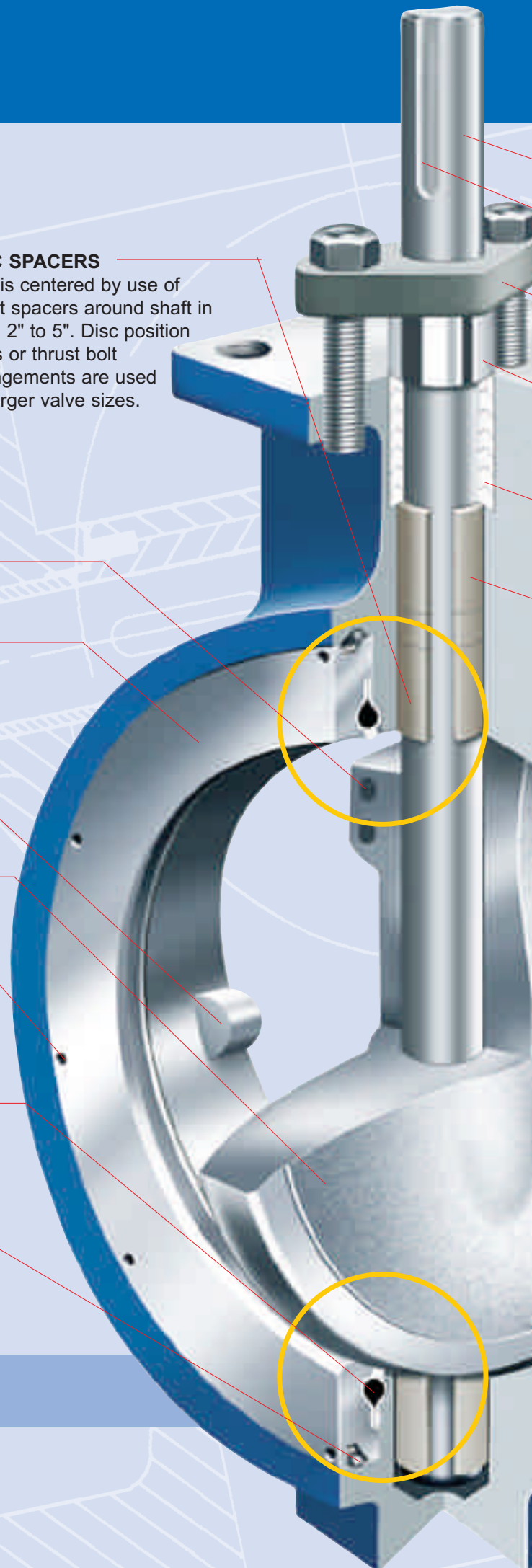



BLOW OUT PROOF SHAFT

Solid shaft provides alignment and rigid support for disc.

KEY

Square key valve-to-operator connection provides an externally controlled failure point upon over-torquing.

GLAND FLANGE

Applies load against packing gland to prevent external leakage. Fully adjustable.

PACKING GLAND

Separate part from gland flange, preventing uneven load distribution against packing.

PACKING

Chevron design TFE prevents external leakage out valve neck to full ANSI hydrostatic shell test pressures (150% of C.W.P.).

BEARINGS

Both above and below the disc, bearings are of composite design: PTFE bonded to epoxy- glass filament wound ring. Used to align shaft, with high capacity, low wear and low friction coefficient.

BODY

ANSI B16.34 design in either wafer or lug configuration.



End Seal Variation

The ANSI 150 14" through 24" sizes feature a two-piece shaft design. The lower shaft utilizes an end seal in the body to prevent external leakage. The component parts include an end seal, an end cap and end cap bolts.



Lower Packing Variation

The ANSI 150 30" through 48"; ANSI 300 14" through 30"; ANSI 600 10" through 16" sizes feature a two-piece shaft design which utilizes a lower packing seal in the valve body to prevent external leakage. The component parts are of the same design used in the packing assembly in the top of the valve body neck.

Principle of Sealing

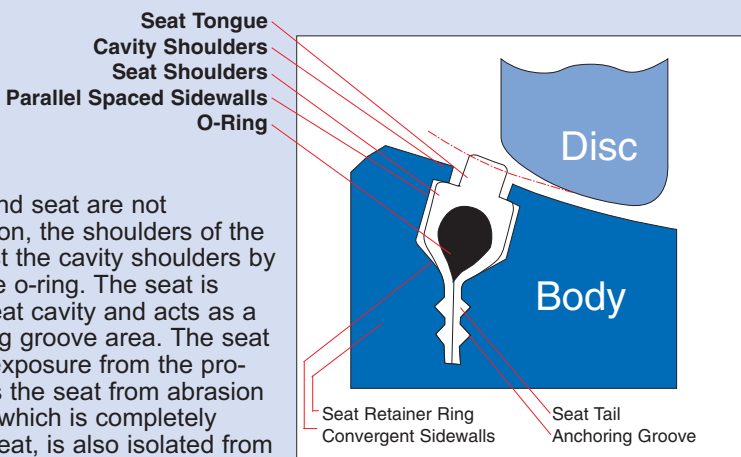

Figure 1

Disc open

In Figure 1, the disc and seat are not engaged. In this position, the shoulders of the seat are forced against the cavity shoulders by the compression of the o-ring. The seat is recessed inside the seat cavity and acts as a gasket in the anchoring groove area. The seat cavity is sealed from exposure from the process fluid and protects the seat from abrasion and wear. The o-ring, which is completely encapsulated by the seat, is also isolated from exposure to the process fluid.

Disc closed, Self-Energized Seal

In Figure 2, the Flowseal disc and seat are engaged, and the process fluid is under low pressure. The edge of the disc, with a larger diameter than the seat tongue, directs movement of the seat radially outward, causing the seat to compress against the convergent sidewalls of the cavity. The elastomeric o-ring imparts a mechanical pre-load between the disc and seat tongue as it is compressed and flattened by the disc; this is the self-energized mode for sealing at vacuum-to-60 psig. As the seat moves radially outward, the seat shoulders move away from the cavity shoulders and open the cavity to the process media.

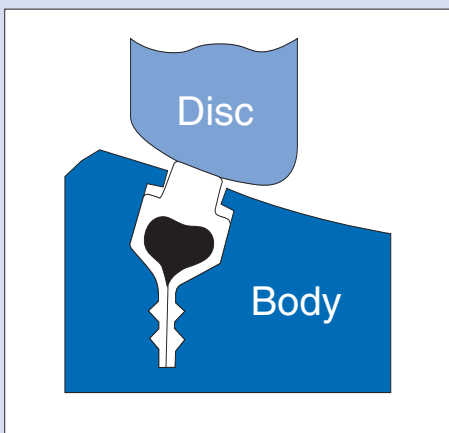

Figure 2

Disc Closed, Pressure-Energized Seal (Seat Upstream)

As line pressure increases, the process fluid enters the sidewall area and applies a load against the parallel-spaced sidewall and convergent sidewall of the seat. The seat and cavity design permits the seat to move axially to the down-stream sidewall, but confines the movement and directs the movement radially inward towards the disc; the higher the line pressure, the tighter the seal between the disc and seat. Because the o-ring is elastic, it is able to flex and deform under loads and return to original shape after removal of the load; it is the rubber which deforms, not the thermoplastic material. This dynamic seal, patented by Flowseal, is totally unique among high performance butterfly valves.

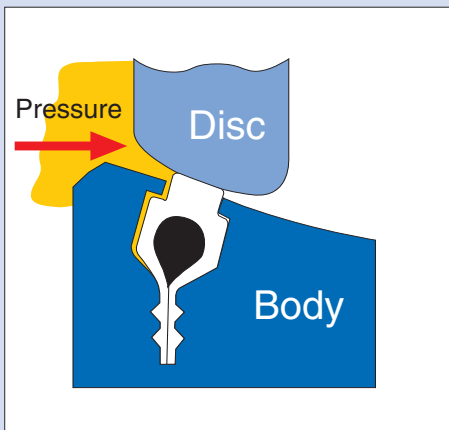

Figure 3

Disc Closed, Pressure-Energized Seal (Seat Downstream)

The Flowseal valve is bi-directional (in some instances, modifications may be required to operate this arrangement for dead end service). The cavity and seat sidewalls are symmetrically designed to permit, confine and direct movement of the seat to the disc to dynamically seal with line pressure in the reverse direction. The disc edge is the segment of a sphere, and the seat is angled towards the disc edge to seal with pipeline pressure in either direction. Recommended installation direction is "SUS" (seat up-stream), as in Figure 3.

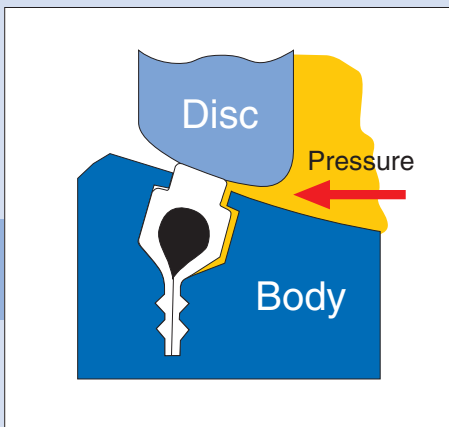

Figure 4

Fire Flow Design



The Flowseal Fire-Flow™ high performance butterfly valve (HPBFV) is a fire-safe, soft seat quarter-turn valve.

The Fire-Flow™ design incorporates a seat which function together to seal off pipeline flow. In normal operation, the soft seat provides a bi-directional "bubble tight" shutoff (zero leakage); in conformance to industry firesafe requirements.

DISC SPACERS

Disc is centered by use of thrust spacers around shaft in sizes 2" to 5". Disc position stops or thrust bolt arrangements are used for larger valve sizes.

WEDGE PINS

Provide positive mechanical attachment of disc to shaft.

RETAINER RING

Retains seat in valve. Standard surface finish is 125 to 200 AARH and is compatible with both standard gaskets and spiral wound gasket designs. Outside diameter is recessed within gasket sealing surface to prevent external leakage.

OVERTRAVEL STOP

Prevents disc from rotating into wrong quadrant.

DISC

360° uninterrupted spherical edge for sealing. Profile is designed for maximum flow and equal percentage control.

SET SCREWS

Cone point screws force wedge ring outward to lock seat retainer in position on valve sizes 2" through 30". Socket head cap screws are used on valve sizes 36" and larger.

FIRE-FLOW SEAT

Bi-directional soft seat design for zero-leakage in normal operation and a metal-to-metal seal after fire, meeting or exceeding industry "fire-safe" specifications.

WEDGE RING

Stainless steel band wedged between valve body and retainer ring by set screws to lock seat and retainer ring in position on valve sizes 2" through 30". Socket head cap screws are used on valve sizes 36" and larger.

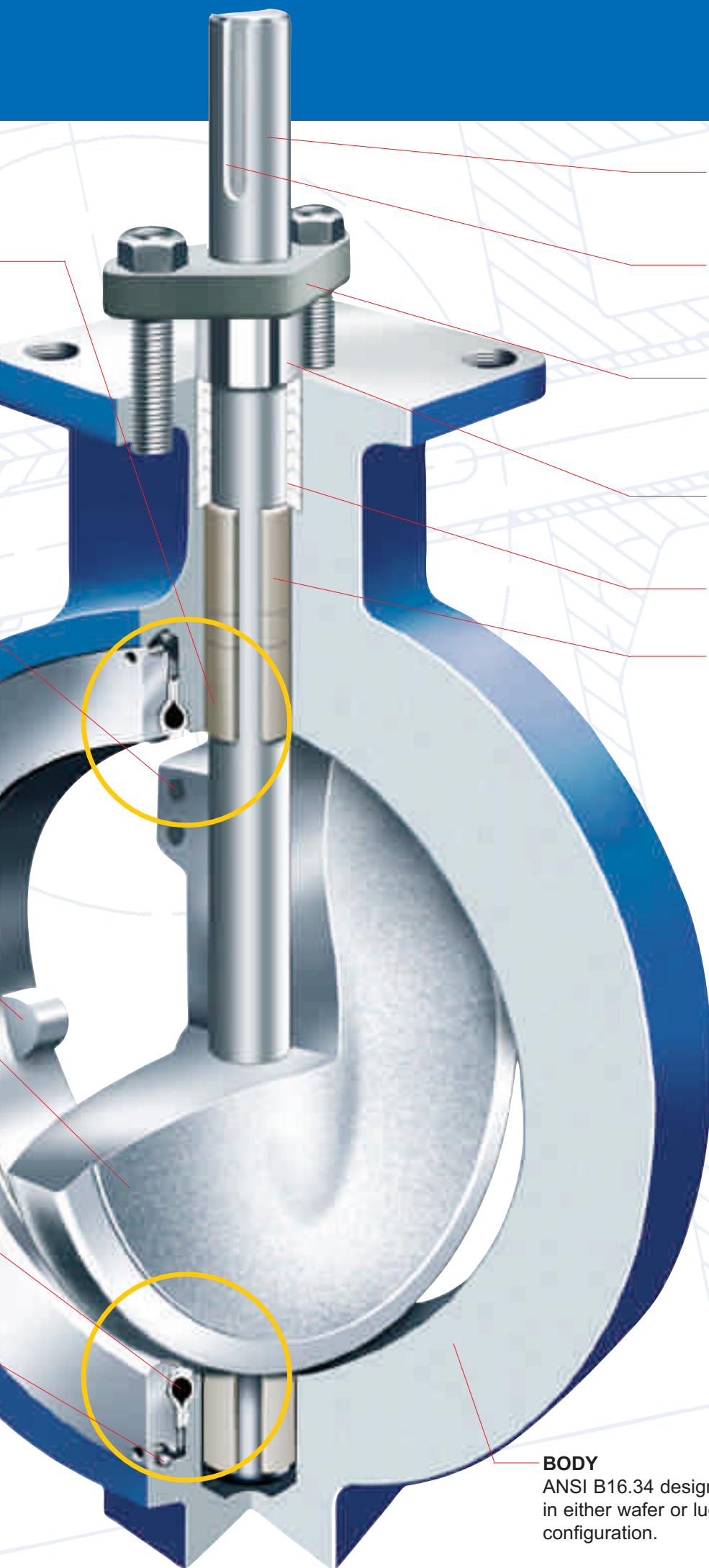

BLOW OUT PROOF SHAFT

Solid shaft provides alignment and rigid support for disc.

KEY

Square key valve-to-operator connection provides an externally controlled failure point upon over-torquing.

GLAND FLANGE

Applies load against packing gland to prevent external leakage. Fully adjustable.

PACKING GLAND

Separate part from gland flange, preventing uneven load distribution against packing.

PACKING

Standard material is graphite.

BEARINGS

Both above and below the disc, bearings are of composite design: PTFE bonded to epoxy-glass filament wound ring. Used to align shaft, with high capacity, low wear and low friction coefficient.



End Seal Variation

The ANSI 150 14" through 24" sizes feature a two-piece shaft design. The lower shaft utilizes an end seal in the body to prevent external leakage. The component parts include an end seal, an end cap and end cap bolts.

BODY

ANSI B16.34 design in either wafer or lug configuration.

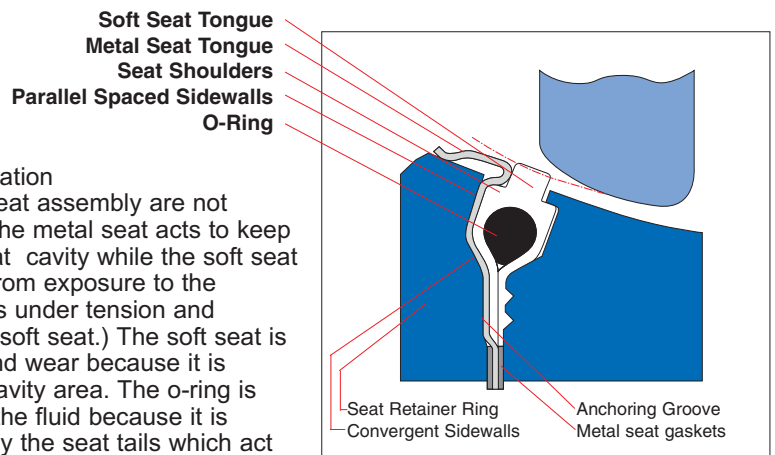

Figure 1

DISC OPEN, Normal Operation

In Figure 1, the disc and seat assembly are not engaged. In this position, the metal seat acts to keep the soft seat inside the seat cavity while the soft seat shoulders seal the cavity from exposure to the process fluid. (The o-ring is under tension and imparts a load against the soft seat.) The soft seat is protected from abrasion and wear because it is recessed inside the seat cavity area. The o-ring is isolated from exposure to the fluid because it is completely encapsulated by the seat tails which act as a (soft) gasket in the anchoring groove area. The metal seat gaskets add further high temperature protection past the anchoring grooves.

Disc Closed, Normal Operation

In Figure 2, the disc and seat assembly are engaged; both the metal seat and the soft seat are in contact with the disc. Under little to no pressure conditions, the metal and soft seats are self-energized. The disc edge, with a larger diameter than the seat tongues, moves the seats radially outward; the metal seat shape, with a mechanical and dynamic flexibility, is designed to be hoop-loaded and impart a spring force against the disc, while the soft seat o-ring is stretched and flattened (without deformation of the thermoplastic material) and imparts a mechanical pre-load against the disc. With increased line pressure, the process fluid enters the cavity sidewall area and applies loads against the seat sidewalls. The cavity design permits the seats to move toward the downstream sidewalls, but confines and directs the movement radially inward towards the disc; the higher the pressure the tighter the seal between the disc and seats. The symmetrical shape and angle of the cavity permit the seal to be bi-directional.

Figure 2

Disc Closed, After Fire (Seat Upstream)

After a fire, with partial or complete destruction of the soft seat, the metal seat maintains metal-to-metal contact with the disc and restricts leakage of the process fluid in conformance to industry fire-safe requirements. With little or no line pressure, the spring force and hoop load of the metal seat maintain a "line contact" seal against the disc edge. Under higher pressures, the process fluid enters the cavity sidewall areas and applies loads against the seat sidewalls (Figure 3). The geometry of the metal seat permits the seat to move axially, but directs the movement radially inward toward the disc; The higher the pressure, the tighter the line contact seal. Graphite gaskets, on both sides of the metal seat tail, seal the anchoring groove and prevent leakage of the process fluid.

Figure 3

Disc Closed, After Fire (Seat Downstream)

The Flowseal Fire-Flow™ valve is bi-directional, however, modifications are required to operate for bi-directional dead end service. The angle and shape of the cavity and metal seat maintains metal-to-metal contact in the event of partial or complete soft seat destruction with line pressure in the reverse direction (Figure 4). While the preferred flow direction is "seat upstream" (SUS), the bi-directional seat design is both self-energized and pressure-energized if the flow direction is "seat downstream" (SDS).

Figure 4



Lower Packing Variation

The ANSI 150 30" through 48"; ANSI 300 14" through 30"; ANSI 600 10" through 16" sizes feature a two-piece shaft design which utilizes a lower packing seal in the valve body to prevent external leakage. The component parts are of the same design used in the packing assembly in the top of the valve body neck.

Specifications

Design: ANSI B16.34
MSS SP-68
MIL-V-24624
API 609

Face to Face: API 609

Flange connection: ANSI B16.5
MSS SP-44

Testing: MSS SP-61
API 598
ANSI / FCI 70-2

Fire-Safe Testing: API 607

Marking: MSS SP-25
CE-Tag acc. PED
97/23 EG

Quality control: MIL-I-45208 A
MSS SP-6
MSS SP-55
ISO 9001

Actuation Options

REVO Pneumatic Actuators



- Compact rack and pinion design
- Travel stops in both directions
- Corrosion protection
- NAMUR solenoid and accessory mounting
- Extruded aluminium body with anodizing

Worm Gear Operators

With standard aluminum handwheel



- High temperature service
- Buried service
- Submersible service
- Marine service

Optional accessories

- Chain wheel
- Output or input shaft extension
- Military operator
- AWWA operator



International Organisation:

Crane Process Flow Technologies SPRL / BV

Avenue Franklin No. 1
B-1300 Wavre
BELGIUM
Tel: +32 10 8184 44
Fax: +32 10 8184 58
www.craneflow.com

Crane Process Flow Technologies India Ltd.

Amar Avinash Corporate Plaza,
7th Floor, Plot No. D2
C.T.S. No. 11/1 to 11/4
Near Inox Multiplex, Bund Garden Road,
Pune 411 001
INDIA
Tel: +91 20 26050922 - 26
Fax: +91 20 26050927
www.craneflow.com

Crane Process Flow Technologies

6 Alexander Road
Belfast
BT6 9HJ
NORTHERN IRELAND
Tel: +44 28 9070 4222
Fax: +44 28 9040 1582
www.craneflow.com

Crane Process Flow Technologies GmbH

IZ NÖ Süd, Str. 2/M6
2355 Wr. Neudorf
AUSTRIA
Tel: +43 2236 682-0
Fax: +43 2236 64353
www.craneflow.com

Crane Process Flow Technologies s.r.l.

Via Pusiano 2
20052 - Monza MI
ITALY
Tel: +39 039 2704 280
Fax: +39 039 2704 450
www.craneflow.com

Crane Process Flow Technologies Ltd.

Grange Road
Cwmbran
Gwent NP44 3XX
UNITED KINGDOM
Tel: +44 163 348 6666
Fax: +44 163 348 6777
www.craneflow.com

Crane Process Flow Technologies GmbH

Heerdter Lohweg 63-71
D-40549 Düsseldorf
GERMANY
Tel: +49 211 59 56 0
Fax: +49 211 59 56 111
www.craneflow.com

Crane Process Flow Technologies

Quatro House
Frimley Road, Camberley
Surrey GU16 7ER
UNITED KINGDOM
Tel: +44 1276 804421
Fax: +44 1276 804422
www.craneflow.com
for sales and technical enquiries originating
in the UK, please contact Crane Process Flow
Technologies Ltd in Cwmbran



Due to constant development and innovation, we reserve the right to make changes to technical specifications as and when required.

© Copyright 2005 Crane Process Flow Technologies Ltd. All rights reserved.
Crane® and FLOWSEAL® are registered trademarks of Crane Corporation.

CRANE®