

# FIGURE 21 WBS APPROVED BS 5163 RESILIENT SEAT GATE VALVE

- Handwheel / Cap Operated
- Non Rising Stem

Manufactured to BS 5163: 5163:1986 type B.  
 Overall Length to BS 5163: 1986.  
 Stem Seals replaceable under pressure.  
 Open / Shut indicators and limit switches available as optional extras.

Maximum pressure – 16 Bar  
 Maximum Temperature - 70°C

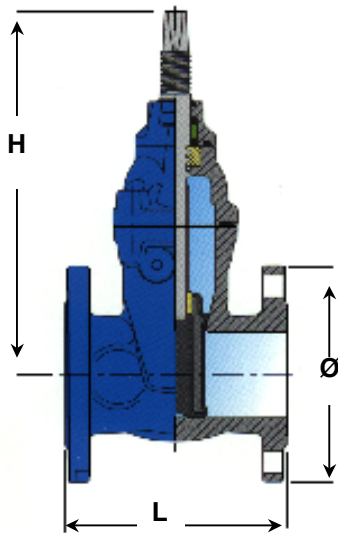

### Construction

Part	Material
Body & Bonnet	Grey Cast Iron GG-25, BS EN 1561 coated with blue epoxy to WIS 4-52-01 Class B+
Stem	Stainless Steel to BS 970 Gr 420 S37
Wedge	Ductile Iron GGG-50, BS EN 1564. Fully encapsulate with EDJ-70 rubber to WBS 9212506
Wedge Nut	DZR Brass to BS 2874 CZ 132
Body, Bonnet Seals	EDJ-70 rubber
Gland Flange Assembly	Ductile Iron GGG-50, BS EN1564, complete with polyamide bush containing 1 wiper & 3NBR 'O' rings
Thrust Collar	DZR Brass BS 2874 CZ132

### Dimensions & Weights

DN mm	Ø mm	L mm	H mm	Wgt Kilos
50	165	178	279	18
80	200	203	294	21
100	220	229	324	28
150	285	267	429	48
200	340	292	531	75
250	405	330	641	114
300	460	356	690	153
350	533	381	867	275
400	580	406	867	304